



# COMPRESSED AIR



...Our goal is to  
work together with our customers  
to reach the best results

The Quality System of Bea Technologies  
has been found to conform to the  
Quality System standard UNI EN ISO 9001:2000  
and is subjected to regularly audits by  
accreditate internationally inspection body.  
Our skilled technicians and our lab team provide  
our customer with high qualified technical assistance.

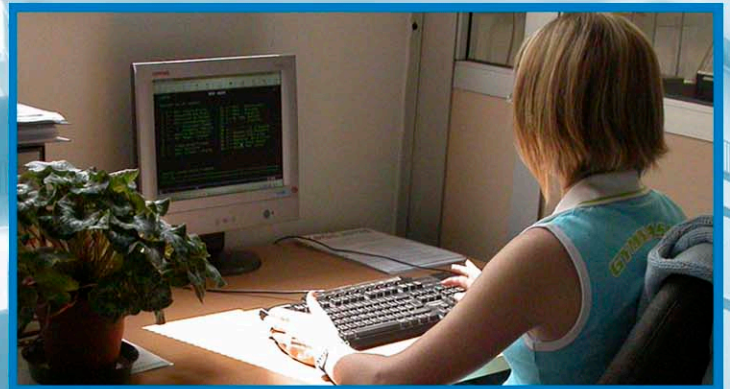

The effort in the research and the continuous testing  
in the field enable us to develop and  
to manufacture high tech filter element.



## OUR MISSION

*Bea Technologies is focused to provide our Customers the highest quality and the most effective products and services.*



A well designed compressed air system reduces maintenance costs of pneumatic devices, provides high purity air grade and improve production efficiency.

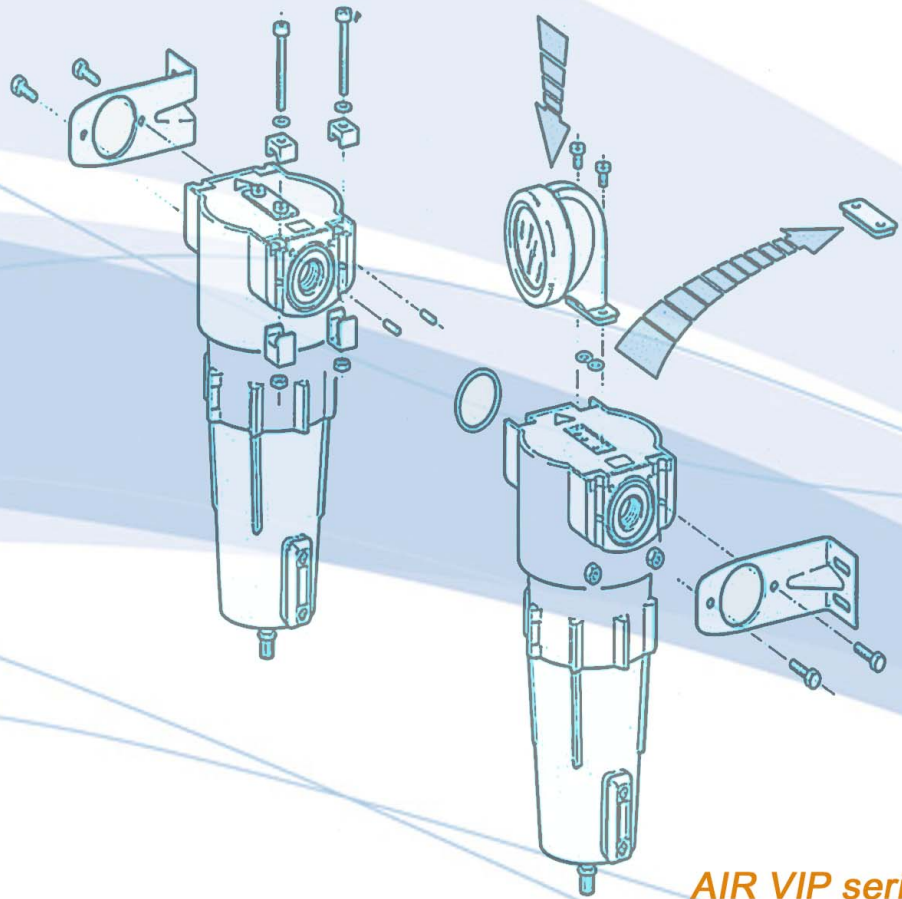

*AIR VIP series  
meet  
"PED" 97/23 CE*

Bea Technologies technical department customizes pressure vessels according to VSR-M-S , ASME , ADMK , EN1345 requirements.

Fluid dynamic and 3D software contribute to enhance the performance of our filtration system.



# RESEARCH & DEVELOPMENT

Bea Technologies experienced team studies the applications to find the best solutions for compressed air treatment. The performances are tested and verified according to ISO and ASTM guidelines.



# PRODUCTION AND QUALITY CONTROL

Our Quality Control department adopts severe testing procedures either on incoming goods, during the production stages, and on the finished products to have products of high quality.



# AIR & GAS FILTER ELEMENT



## **ARS RM grade compressed air & gas pre filtration**

Pleated filter elements RM grade (particles removal  $10\ \mu\text{m}$  – residual oil down to  $15\ \text{mg}/\text{m}^3$  at  $21^\circ\text{C}$ ) retains mist and solid particles. They are generally used to protect accumulators, dryers and as pre filter upstream RB & RA grade cartridges.

## **ARS RF grade high efficiency particle filtration**

Pleated filter elements RF grade (particles removal  $1\ \mu\text{m}$ ) are used to remove dust, fine particles and rust; they are generally used downstream the adsorption dryers to retain alumina or molecular sieve dust.



## **ARS RB grade oil removal & compressed air filtration**

Pleated filter elements RB grade (particles removal  $1\ \mu\text{m}$  – residual oil down to  $0,1\ \text{mg}/\text{m}^3$  at  $21^\circ\text{C}$ ) are generally used after dryers when the compressed air is used for general purpose. They are also used as pre filter upstream RA & CA grade cartridges.



## **ARS RA grade high efficiency oil removal compressed air filtration**

Pleated filter elements RA grade (particles removal  $0,01\ \mu\text{m}$  – residual oil down to  $0,01\ \text{mg}/\text{m}^3$  at  $21^\circ\text{C}$ ) are used to obtain compressed air with high standard of purity. Efficiency 99,9999% related to mist particles of  $0,3\ \mu\text{m}$ , is suitable to protect adsorption dryers in paint plants, electronic, food & beverage and textile industries.



## **ARS CA grade compressed air odours reduction and aerosol removal**

Pleated filter elements CA grade (oil vapour down to  $0,003\ \text{ppm}$  at  $21^\circ\text{C}$ ) are manufactured with synthetic fibers impregnated with activated carbon. They are used in food & beverage, pharma, textile and electronic market to reduce odours and oil vapour content. These filter elements must be protected installing upstream RA grade cartridge.



## **STERYFLON gas & air sterilizing filter element**

STERYFLON are used as sterilizing filter element in compressed air and gas for pharma, electronic and bio-food applications.

They are manufactured with hydrophobic expanded PTFE membrane with absolute filtration of  $0,1\ \mu\text{m}$  e  $0,2\ \mu\text{m}$ . The materials of construction meet the bio-safety requirements of FDA and USP guidelines. The manufacturing is performed in a controlled environment.



### **FINCELL high efficiency filter element**

FINCELL filter cartridges are manufactured from pleated layers of glass borosilicate and resin impregnated cellulose media. The resulting high media strength virtually eliminates fibre and contaminant release even in the presence of variable differential pressures. The high surface area provides for long service life.

Fincell, filter element, available in different filtration ratings, is used to remove particle from compressed gas & air.



### **REVERSE FINCELL coalescer filter element**

REVERSE FINCELL filter element removes oil and water aerosols from compressed gas (air, nitrogen, hydrogen etc.).

The cartridge is manufactured from pleated layers of borosilicate microfiber and resin impregnated cellulose media with stainless steel inner core and outer cage.

Reverse Fincell cartridges are available in two filtration efficiency grades to achieve effluent gas with residual aerosol content below 1 mg/m<sup>3</sup> or 0,01 mg/m<sup>3</sup>.



### **OIL SEP & FIN SEP high efficiency air-oil separator**

OIL SEP e FIN SEP air-oil separators remove oil mist from compressed air or vacuum generated by rotary compressors or lubricated vacuum pumps.

Bea Technologies is able to customize Oil Sep & Fin Sep filter element, to be installed inside the compressor in order to meet OEM requirements. Oil Sep has a stratification made of wounded layers of microfibers with different porosity, while Fin Sep is the pleated version. Both are able to reduce the oil mist content down to 1 – 2 mg/m<sup>3</sup>.

## **METALLIC FILTER ELEMENT**



### **SOLINOX regenerable filter element**

SOLINOX filter elements are used for high efficiency filtration and are regenerable. They have a very high mechanical resistance up to differential pressure of 20 bar and can withstand extreme temperatures from -30°C to +300° C.

Solinox cartridges are constructed entirely in stainless steel, with a fine stainless steel mesh wrapped around a robust stainless steel inner core and metal end-caps. Solinox cartridges contain no glues or resins. .



### **PORAL INOX sintered stainless steel filter element**

PORAL INOX filter element retains particles in filtration of fluid at high temperature and pressure. The filtering media is made by sintering Stainless Steel powder with controlled porosity.

Ends welded by TIG process with a wide array of end fittings are available, including flat gasket, threaded and bayonet connections.

Poral Inox elements are versatile and extremely robust. Typical applications include filtration of liquids, gases, steam and corrosive chemicals.

On request, PORAL MONEL and PORAL INCONEL are available for extremely highly corrosive gases or liquids.

# MEDICAL VACUUM FILTER ELEMENT



## VACUUM VIP medical vacuum application filter element

VACUUM VIP filters are designed specifically to protect the suction side of vacuum pumps from exposure to bacterial contamination and consequently to prevent contamination of the exhaust air.

Vacuum Vip are used in hospitals labs and critical medical applications. The filter element have been designed to have a long service and minimize pressure drops. Test performed according to BS 3928 guidelines have proven that Vacuum Vip cartridges have 99.9998% of efficiency.

## HOUSINGS



### AIR-VIP CDF aluminium housings

CDF series has a complete range of casted aluminum housings for compressed air treatment. All the housing are fitted with ARS filter element series.

CDF series is available in 14 different configurations with flow rates from 20 to 2300 m<sup>3</sup>/h.

The main features are: anodizing treatment of internal and outside surface before painting, filter element with radial OR sealing and limited clearance (only 6 cm), pressure relief hole device, liquid indicator, optional differential gauge, automatic drain valve, connection mounting kit.



### AIR-VIP ACF housings

ACF series, manufactured in carbon or stainless steel, are available in ten different configurations with flow rates from 1600 to 33600 m<sup>3</sup>/h and connections from DN 80 to DN 300.

### MAB - GFF - GHS - PAT housings

MAB – GHS – PAT - GFF housings available in carbon steel and stainless steel 316 are used for gas filtration with operating pressure over 16 bar. These housings are fitted with filter element size 2001 available in a wide range of material and filtration rating.

## DRYERS



### DRY-VIP refrigeration dryer technology

DRY VIP refrigeration dryers reduce the content of water vapor in compressed air nearly to + 3 °C dew point.

Dry Vip incorporate energy saving technology enhanced by thermal mass and direct expansion systems.

Dry Vip series is available in 18 different configurations with air flow rate from 35 to 2250 m<sup>3</sup>/h.



### DRY-PLUS adsorption dryer technology

DRY PLUS adsorption dryers, with cold or hot regeneration, reduce the content of water vapor in compressed air to a dew point below -40 °C with activated alumina and -60 °C with molecular sieve.

Regeneration cycle uses a small amount of dried air that, expanded through the adsorbent bed, catches the humidity; the wet air is discharged to outside through a silencer.

Dry Plus series is available in twelve different configurations with flow rate from 10 to 1500 m<sup>3</sup>/h.

# WATER VAPOR CONDENSATE TREATMENT & ACCESSORIES



## OILVIP oily condensate separation system

The OILVIP system reduces concentration of lubricating oil in the condensates generated by equipment installed in compressed air and gas rig, such as compressors, heat exchangers, centrifugal separators, refrigeration dryers and accumulator tanks.

The Oilvip system is capable to progressively coalesce the micro drops of oil dispersed in the condensate. It allows the formation of larger droplets, which rise to the surface, where they are conveyed towards an external collection container for easy oil disposal.

Large activated carbon stage, protected by prefilter to reduce bulk contamination, improves water quality absorbing the smallest drops of oil. The purified condensate water is discharge into the drain.

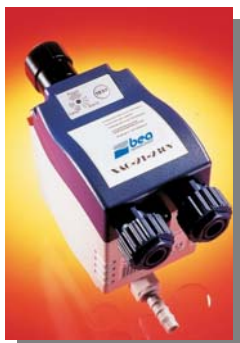

## XAC-21 automatic drain valve with electronic level control

XAC-21 automatic drain is designed to remove condensates from compressed air systems, without the unnecessary loss of valuable compressed air.

The automatic drain is supplied with a single detection capacitive level sensor and has no moving parts. This results in reliable condensate discharge and eliminates the need for routine maintenance.

The unit is also suitable in applications where extremely emulsified condensate is found.



## XAE-950T electronic drain device

XAE-950T perform every two minutes a check test to detect the presence of condensate. XAE-950T monitors the level of condensate collected and uses this signal to open the discharge valve. Even in the absence of condensate during each control cycle, a discharge of a few tenths of a second is carried out in order to assure the elimination of air bubbles that could inhibit the accuracy of the sensors.

XAE-950T is available with different power supply to match Customer requirements.



## XAD-651 float level drain device

XAD-651 is an automatic float condensate drain with casted aluminum body suitable for installation where large amount of condensate is present in the system. The operation can be performed both automatically or manually.



## XAM-100 & XAM-200 differential pressure gauge

XAM-100 differential gauge measures the pressure difference between the inlet and outlet of the filter assembly, in a range from 0 to 1,4 bar. The scale centrally set at "0" allows the mounting on both side of the filters.

XAM-200, differential pressure gauge identifies the convenient time for the change out of the filter element. The pressure gauge has on both side a scale in two colors in a range from 0 to 0,7 bar. No pressure behind lens and special membrane gaskets provide XAM 200 a great safety and accuracy.

XAM-200EC series includes the remote control interface.

ISO 8573-1:2001 defines the standard of quality according to the application where compressed air is used.

## Contaminants and purity classes ISO 8573-1:2001

PURITY CLASS	SOLIDS Number of particles per m <sup>3</sup>			WATER Dew Point at pressurized conditions	OIL CONCENTRATION ( Mist included ) mg/m <sup>3</sup>
	0.1–0.5 μ	0.5–1 μ	1–5 μ		
1	100	1	0	-70 °C	0,01
2	100.000	1.000	10	-40 °C	0,1
3	-	10.000	500	-20 °C	1
4	-	-	1.000	+3 °C	5
5	-	-	20.000	+7 °C	-
6	-	-	-	+10 °C	-

## Cross reference between Bea products and purity classes

PURITY CLASS	Particles removal	Water removal	Oil removal
1	STERYFLON - SL	DRY-PLUS / -70C°	ARS-RB + ARS-RA + ( ARS-CA )
2	ARS-RB + ARS-RA	DRY-PLUS / -40C°	ARS-RB + ( ARS-RA )
3	ARS-RB / ARS-RF	DRY-PLUS / -20C°	ARS-RB
4	ARS-RF	DRY-VIP / + 3°C	ARS-RF
5	ARS-RM	DRY-VIP / + 7°C	
6	SOLINOX	DRY-VIP / +10°C	

## Main application

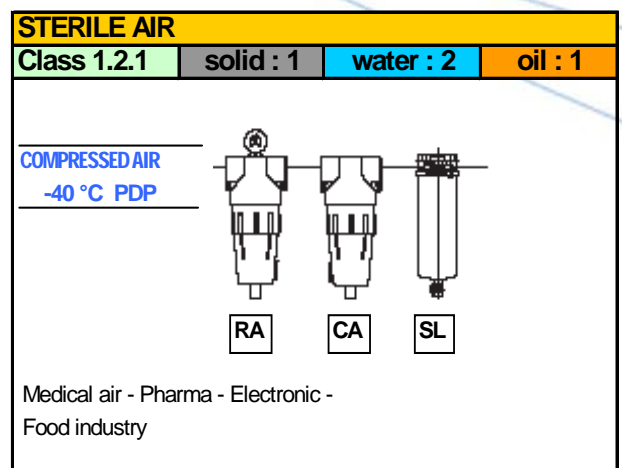
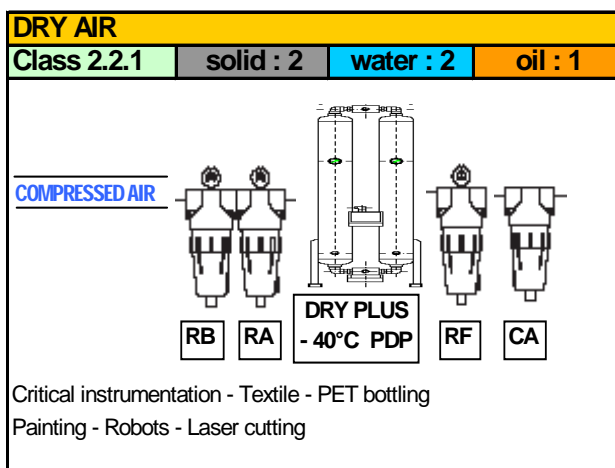
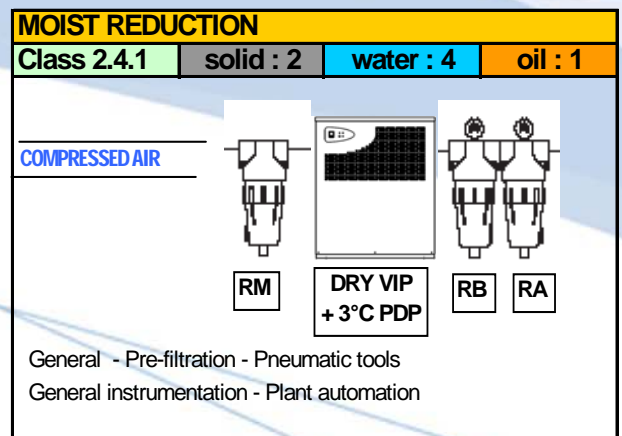
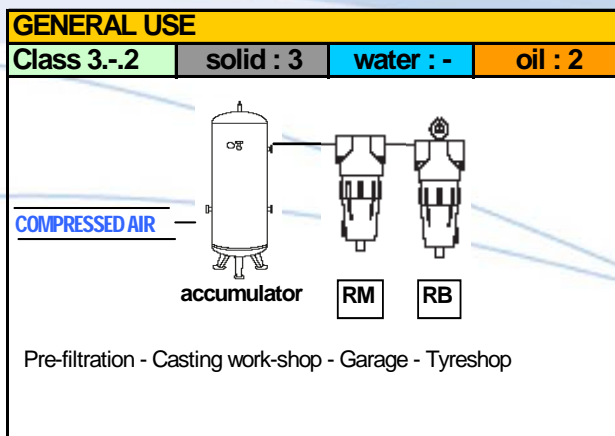

# PED 97/23/CE

**BUREAU VERITAS**  
**ATTESTATION D'APPROBATION DE SYSTÈME DE QUALITÉ**  
**CERTIFICATE OF QUALITY SYSTEM APPROVAL**  
**N° CE-PED-H-BEA001-05-BVI**

Bureau Veritas S.A. is a Notified Body under the number 1370

BUREAU VERITAS

ANNEXE à l'attestation d'approbation de système de qualité  
 ANNEX to the certificate of quality system approval  
**N° CE-PED-H-BEA001-05-BVI**

Liste des équipements concernés  
 List of the concerned equipment

- MONOCARTRIDGE FILTERS
- PLURICARTRIDGE FILTERS
- BASKET FILTERS & BAGS FILTERS
- VERTICAL LEAVES FILTERS
- HORIZONTAL LEAVES FILTERS
- SELF-CLEANING FILTERS
- DUOMATIC

Fabricant (Nom) / Manufacturer (Name): **BEA TECHNOLOGIES S.p.A.**  
 Via Newton, 4 - 5/7 - 8a - 20016 PERO (MI) - Italy

Adresse / Address: **Vessels**

Marque commerciale / Trade Mark: **Vessels**

Description des équipements / Equipment description: **Pressure filters with filtering elements**  
 (see attached list for more details)

Identification des équipements concernés (liste en annexe le cas échéant) / Identification of equipment concerned (list attached where necessary): **02/01/2008**

Cette attestation est valable jusqu'au / This certificate is valid until: **02/01/2008**

Le maintien de l'approbation est soumis à la réalisation par le Bureau Veritas des audits, essais et vérifications selon le contrat signé par le fabricant et le Bureau Veritas. The approval is conditional upon the surveillance audits, tests and verifications to be carried out by Bureau Veritas as per the provisions stated in the agreement signed by both the manufacturer and Bureau Veritas.

Cette attestation est présumée nulle et le fabricant supporte seul les conséquences de son utilisation, si les assurances - données par le fabricant lors de la demande d'intervention - en matière (a) d'application de son système qualité approuvé, (b) de conformité de son équipement au type et (c) d'autres obligations applicables. This certificate shall be deemed to be void and the manufacturer shall alone bear any consequences pursuant to its use, where the manufacturer fails to comply with his undertakings as per the agreement and tests on the final product, and generally where the manufacturer fails in particular to comply with any of his obligations under directive nr 97/23/CE of 29 may 1997 as amended in the applicable law(s).

Stato / Made at: **MILAN**

Le / On: **02/01/2008**

Code d'enregistrement / Registration code: **NN-PED0001-01**

La présente attestation est soumise aux Conditions Générales de Service de Bureau Veritas jointes à la demande d'intervention signée par le demandeur. This certificate is subject to the terms of Bureau Veritas General Conditions of Service attached to the agreement signed by the applicant.

© BUREAU VERITAS S.A., 2001

MM46505CP/01 BV ITA 40.04.5699 Pag. 1/2

http://www.bureauveritas.com/pef

## PRESSURE EQUIPMENT DIRECTIVE & QUALITY SYSTEM

**DET NORSKE VERITAS**  
**QUALITY MANAGEMENT SYSTEM CERTIFICATE**

Certificato No. / Certificate No. **CERT - 00190 - 94 - AQ - MIL - SINCERT**

Si attesta che / This certifies that

IL SISTEMA DI GESTIONE PER LA QUALITÀ DI / THE QUALITY MANAGEMENT SYSTEM OF

**BEA TECHNOLOGIES S.p.A.**  
 Via Newton, 4 - 5/7 - 8/a - 20016 Pero (MI) - Italy

È CONFORME AI REQUISITI DELLA NORMA PER I SISTEMI DI GESTIONE PER LA QUALITÀ  
 CONFORMS TO THE QUALITY MANAGEMENT SYSTEM STANDARD

**UNI EN ISO 9001: 2000 (ISO 9001: 2000)**

Questa certificazione è valida per il seguente campo applicativo:  
 This certificate is valid for the following product or services:  
 (Ulteriori chiarimenti riguardanti lo scopo e l'applicabilità dei requisiti della normativa si possono ottenere consultando l'organizzazione certificata)  
 (Further clarifications regarding the scope and the applicability of the requirements of the standard(s) may be obtained by consulting the certified organization(s))

**Progettazione, produzione, commercializzazione ed assistenza di elementi filtranti ed accessori, recipienti a pressione, tecnologie di separazione e sistemi filtranti**  
 Design, manufacture, trade and servicing of filter elements and devices, pressure vessels, separation technologies and filtration systems

Luogo e data / Place and date: **Agrate Brianza (MI), 2004-10-27**

Data Prima Emissione: / First Issue Date: **1994-02-07**

per l'Organismo di Certificazione / for the Accredited Unit: **Det Norske Veritas Italia S.r.l.**

Lead Auditor: **RENZO SERRA**

Settore EA: **18**

**SINCERT**  
 ACCREDITED ORGANIZATION

500 Registrazione N. 0034  
 950A Registrazione N. 0030  
 9700 Registrazione N. 0030

Member Body Accredited to Major Recognition EA & 187  
 Signatory of EA and 187 Mutual Recognition Agreements

Leonardo Omodeo Zorini  
 Management Representative

La validità del presente certificato è subordinata a sorveglianza periodica (ogni 6, 9 o 12 mesi) e al riesame completo del sistema con periodicità triennale.  
 The validity of this certificate is subject to periodical audits (every 6, 9 or 12 months) and the complete re-assessment of the system every three years.  
 See annex to the certificate for further details regarding the frequency of audits and the complete re-assessment of the system every three years.

# UNI EN ISO 9001:2000

# bea

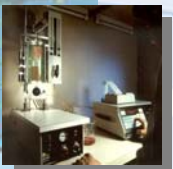
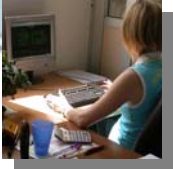

Bea Technologies is dedicated to provide Customers with the highest quality and most effective products and services.

## Customer Service

A highly experienced team of engineers and filtration experts is available to advise our Customers regarding the selection of the best performing and most cost effective filter for their particular application. Please contact us to arrange for an initial evaluation and on-site trial.

## Laboratory Service

Bea Technologies has a fully equipped laboratory with a broad range of test rigs and instrumentation to conduct laboratory trials to help Customers to optimise their production processes.

## Quality System

The Quality Management System implemented by Bea Technologies SpA has been certified according to:

UNI EN ISO 9001:2000  
CERT-00190-94-AQ-MIL-SINCERT

